

LC/1K TE

tavola estraibile / pull-out table



DATI TECNICI / Technical Data

dim. utili/ useful dim.	900 x 900 x 850 H.
dim. ingombro/ overall	2200 x 950 x 1950 H.
portelle/ doors	nr. 1
tavola rotante/ rotat. table	Ø mm. 800
ciclone/ cyclone	Ø mm. 350 - 900 H.
peso/ weight	kg. 250
portata carico/ load	kg. 400
elettrovent./ electric fan	HP. 0,75
consumo aria/ air consump.	110>780 lt/1' (1>7 BAR)
alim. elettrica/ power sup.	230/400 V 50 Hz

CARATTERISTICHE

Sabbiatrici / pallinatrice compatta Mod. LC/1KTE è indicata per medie/grandi produzioni con garanzia di omogeneità e grado di finitura costante. La tavola rotante montata su carrello scorrevole e cuscinetti a tenuta stagna, permette un facile carico scarico pezzi e la rotazione manuale di particolari pesanti e con forme complesse. Il ciclone a funzionamento selettivo con ventilatore industriale (HP 0,75) consente una ottimale separazione delle polveri.

Consigliamo l'utilizzo del filtro certificato Lampugnani in armadio metallico Mod. **SE/1** o **LAC/10**.

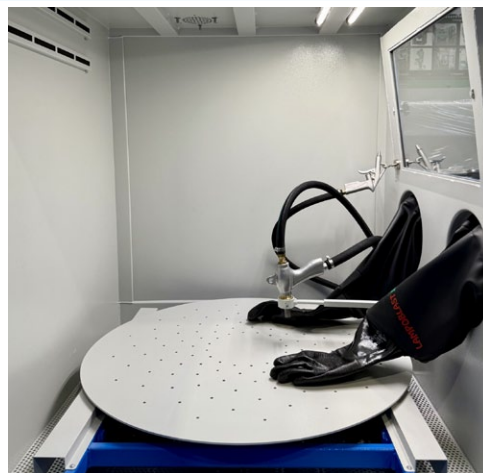

Features

LC/1KTE shot-peening machine with compact dimension is designed for medium / large production with guarantee of uniformity and constant finishing degree.

The rotating table mounted on a sliding trolley installed on a set of bearings, can be used for manual rotation of heavy pieces with complex forms, making sandblasting and shot-peening operations easier.

The cyclone with industrial fan (0.75 HP) provides an excellent separation of powders.

*We recommend to use Lampugnani certified cartridge Filter in steel closet Model **SE/1** or **LAC/10**.*



Funzionamento Ciclone e Filtro
Cyclone and Filter operation

Mod. CL/40
Ciclone / Cyclone

Mod. SE/1
Filtro / Filter

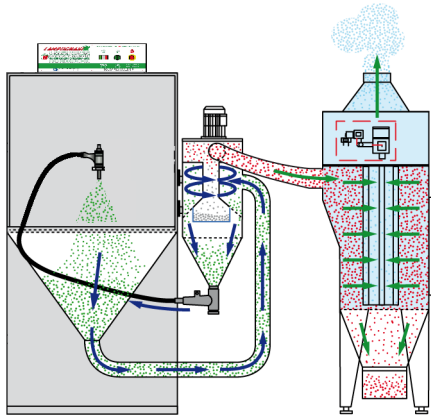

Il **Ciclone** tramite forza centrifuga seleziona e separa le polveri che si creano durante il ciclo di sabbiatura e pallinatura. Il **Filtro** a cartuccia certificato Mod. SE/1 trattiene le polveri di lavorazione, garantisce un ottimo equilibrio dell'impianto.

The cyclone by centrifugal force selects and separates the powders that are created during the sandblasting and shot-peening cycle. The certified cartridge filter Mod. SE/1 retains the processing powders, ensures an excellent balance of the sandblasting system.

dim. ingombro/overall dim.
mm. 600 x 500 x 1200 H.

elettroventilatore/electric-fan
HP. 0.75

peso /weight
kg. 30

setaccio vagliatore
sieve

(di serie/stock)

dim. ingombro/overall dim.
mm. 2250 x 1600 x 1750 H.

superficie filtrante /filt. surface
m² 3

peso /weight
kg. 90

pulizia cartuccia/cartridge clean
automatica/automatic

(optional)

Dimensioni e Ingombri mm. / Useful and Overall Dimensions mm.

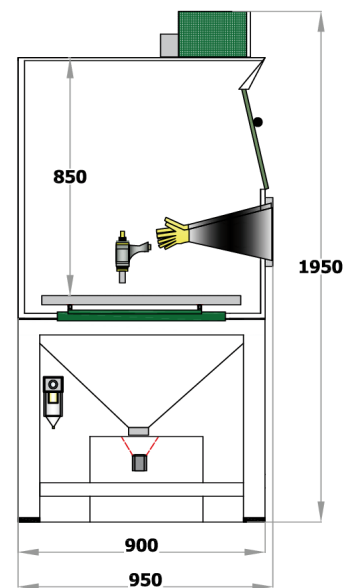
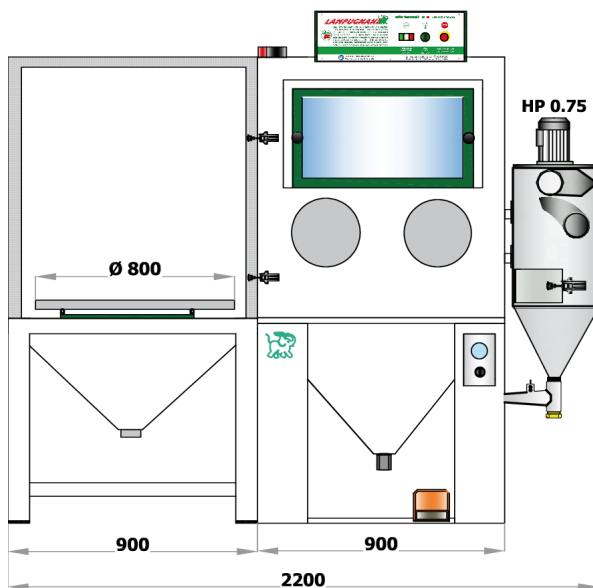

Microsfere e Abrasivi / Microbeads and Abrasives



MICROSFERE VETRO
glass microbeads



MICROSFERE CERAMICA
ceramic microbeads



CORINDONE BRUNO
red-brown corundum



CORINDONE BIANCO
white corundum



GRANIGLIA ANGOLARE
cast iron

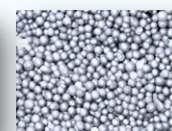

GRANIGLIA SFERICA
steel beads



GRANULI PLASTICI
plastic granules